

RL1001CT THRU RL1007CT

GLASS PASSIVATED SILICON RECTIFIER

REVERSE VOLTAGE: 50 to 1000 VOLTS

FORWARD CURRENT: 10.0 AMPERE

FEATURES

- Low forward voltage drop
- High current capability
- High capability
- High surge current capability

MECHANICAL DATA

Case: Molded plastic, TO-220

Epoxy: UL 94V-O rate flame retardant

Terminals: Leads solderable per MIL-STD-202 method 208 guaranteed

Polarity: As marked

Mounting position: Any

Weight: 0.08ounce, 2.24gram

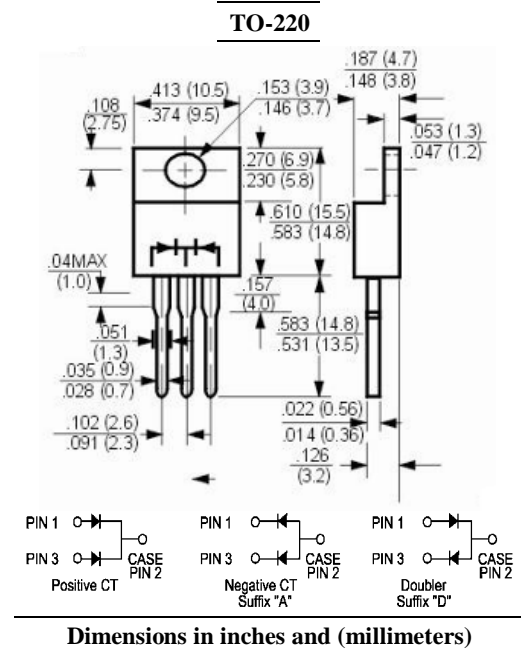

Maximum Ratings and Electrical Characteristics

Ratings at 25°C ambient temperature unless otherwise specified.

Single phase, half wave, 60Hz, resistive or inductive load.

For capacitive load, derate current by 20%.

	Symbols	RL1001CT	RL1002CT	RL1003CT	RL1004CT	RL1005CT	RL1006CT	RL1007CT	Units
Maximum Recurrent Peak Reverse Voltage	V_{RRM}	50	100	200	400	600	800	1000	Volts
Maximum RMS Voltage	V_{RMS}	35	70	140	280	420	560	700	Volts
Maximum DC Blocking Voltage	V_{DC}	50	100	200	400	600	800	1000	Volts
Maximum Average Forward Rectified Current .375" (9.5mm) Lead Length at $T_C=100^\circ\text{C}$	$I_{(AV)}$	10.0							Amp
Peak Forward Surge Current, 8.3ms single half-sine-wave superimposed on rated load (JEDEC method)	I_{FSM}	125							Amp
Maximum Forward Voltage at 5.0A DC and 25°C	V_F	1.1							Volts
Maximum Reverse Current at $T_C=25^\circ\text{C}$ at Rated DC Blocking Voltage $T_C=100^\circ\text{C}$	I_R	5.0 50							uAmp
Typical Junction Capacitance (Note 1)	C_J	30							pF
Typical Thermal Resistance (Note 2)	$R_{\theta JC}$	3							°C/W
Operating and Storage Temperature Range	T_J, T_{stg}	-55 to +150							°C

NOTES:

1- Measured at 1 MHz and applied reverse voltage of 4.0 VDC.

2- Thermal Resistance from Junction to Case per Leg Mounted on Heatsink.

RL1001CT THRU RL1007CT

GLASS PASSIVATED SILICON RECTIFIER



RATINGS AND CHARACTERISTIC CURVES

FIG.1- MAXIMUM FORWARD CURRENT DERATING CURVE

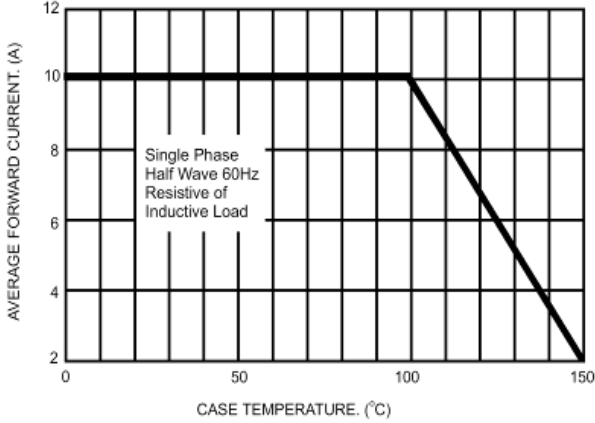

FIG.2- MAXIMUM NON-REPETITIVE FORWARD SURGE CURRENT

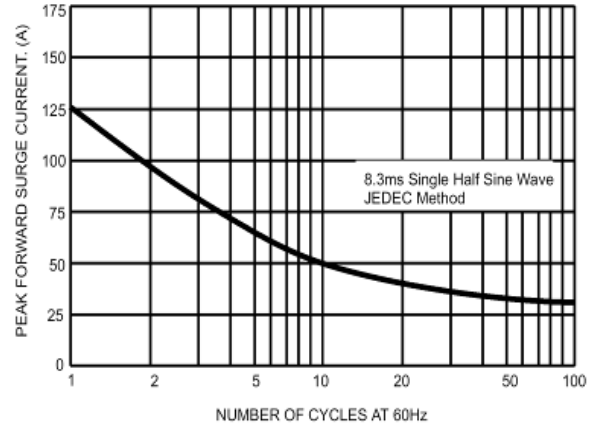

FIG.3- TYPICAL INSTANTANEOUS FORWARD CHARACTERISTICS PER LEG

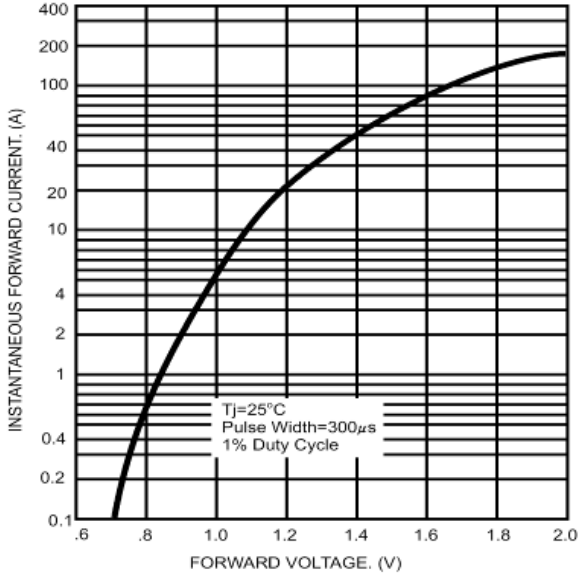

FIG.4- TYPICAL REVERSE CHARACTERISTICS PER LEG

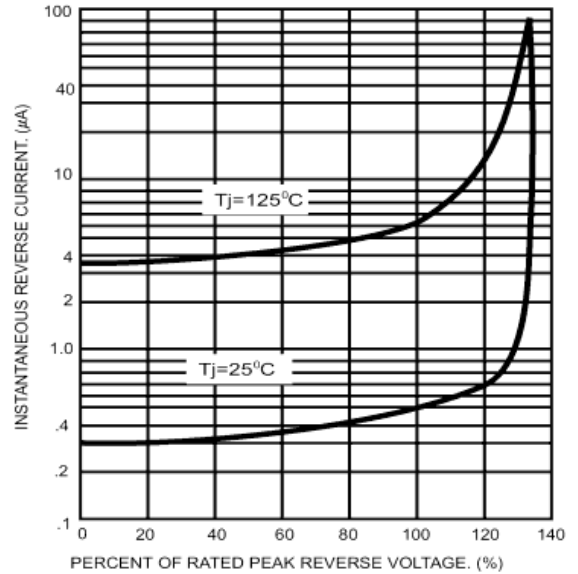

FIG.5- TYPICAL JUNCTION CAPACITANCE

