

2SC2073U

NPN Silicon Epitaxial Planar Transistor

General purpose amplifier and high voltage application

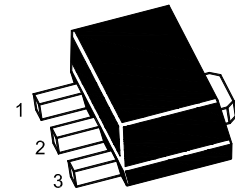

1.Base 2.Collector 3.Emitter
SOT-89 Plastic Package

Absolute Maximum Ratings ($T_a = 25^\circ\text{C}$)

Parameter	Symbol	Value	Unit
Collector Base Voltage	V_{CBO}	160	V
Collector Emitter Voltage	V_{CEO}	160	V
Emitter Base Voltage	V_{EBO}	7	V
Collector Current	I_C	1	A
Peak Collector Current (Single pulse, $t_p = 300 \mu\text{s}$)	I_{CP}	2	A
Total Power Dissipation	P_{tot}	0.5 1 ¹⁾	W
Junction Temperature	T_j	150	$^\circ\text{C}$
Storage Temperature Range	T_{stg}	- 55 to + 150	$^\circ\text{C}$

¹⁾ mounted on a ceramic substrate (250 mm² x 0.8 t)

Characteristics at $T_a = 25^\circ\text{C}$

Parameter	Symbol	Min.	Typ.	Max.	Unit
DC Current Gain at $V_{CE} = 5 \text{ V}$, $I_C = 30 \text{ mA}$	h_{FE}	200	-	400	-
Collector Base Cutoff Current at $V_{CB} = 160 \text{ V}$	I_{CBO}	-	-	0.1	μA
Emitter Base Cutoff Current at $V_{EB} = 4 \text{ V}$	I_{EBO}	-	-	0.1	μA
Collector Base Breakdown Voltage at $I_C = 100 \mu\text{A}$	$V_{(BR)CBO}$	160	-	-	V
Collector Emitter Breakdown Voltage at $I_C = 1 \text{ mA}$	$V_{(BR)CEO}$	160	-	-	V
Emitter Base Breakdown Voltage at $I_E = 100 \mu\text{A}$	$V_{(BR)EBO}$	7	-	-	V
Collector Emitter Saturation Voltage at $I_C = 500 \text{ mA}$, $I_B = 50 \text{ mA}$ at $I_C = 200 \text{ mA}$, $I_B = 2 \text{ mA}$	$V_{CE(sat)}$	-	-	0.5 1	V
Base Emitter Saturation Voltage at $I_C = 500 \text{ mA}$, $I_B = 50 \text{ mA}$	$V_{BE(sat)}$	-	-	1.2	V
Transition Frequency at $V_{CE} = 5 \text{ V}$, $I_C = 50 \text{ mA}$	f_T	-	150	-	MHz
Collector Output Capacitance at $V_{CB} = 10 \text{ V}$, $f = 1 \text{ MHz}$	C_{ob}	-	10	-	pF

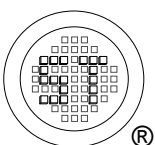

SEMTECH ELECTRONICS LTD.



Dated : 20/02/2016 Rev: 03

Fig. 1 $P_C - T_a$

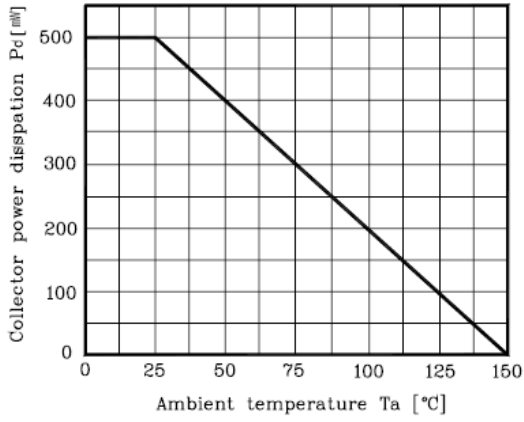

Fig. 2 $I_C - V_{BE}$

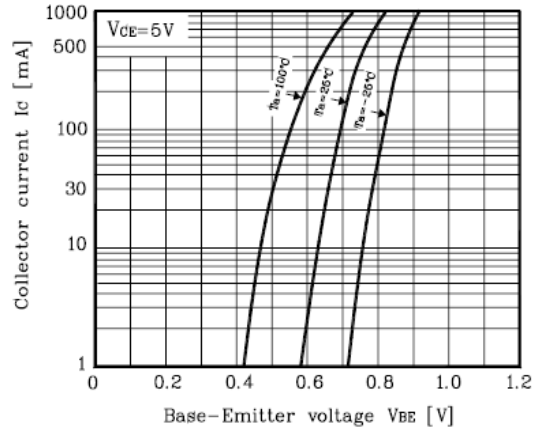

Fig. 3 $V_{CE(sat)} - I_C$

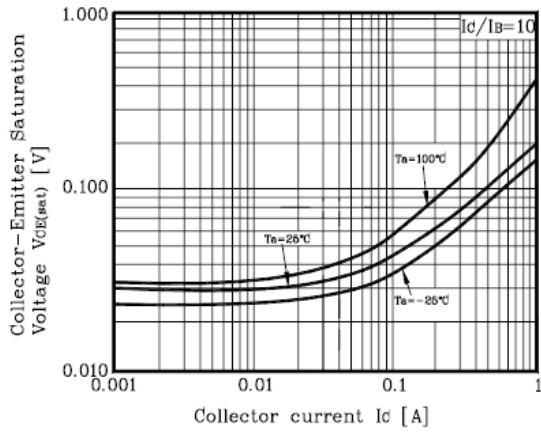

Fig. 4 $I_C - V_{CE}$

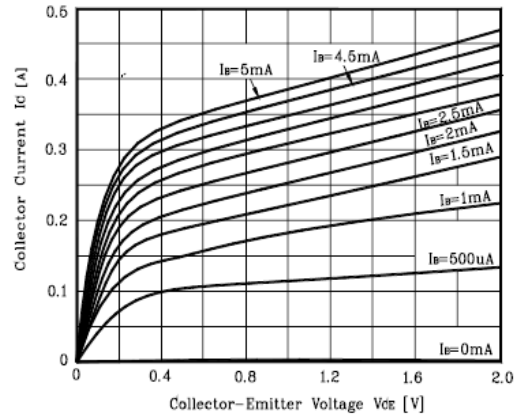
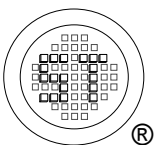
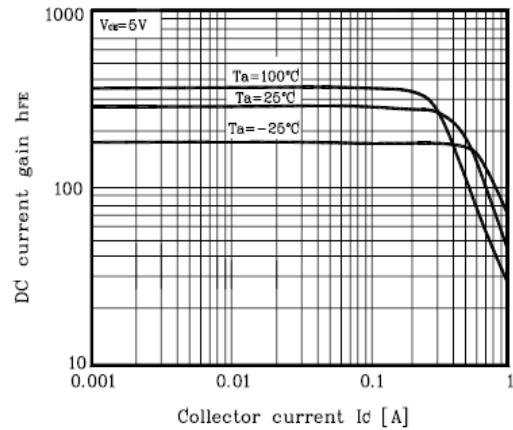
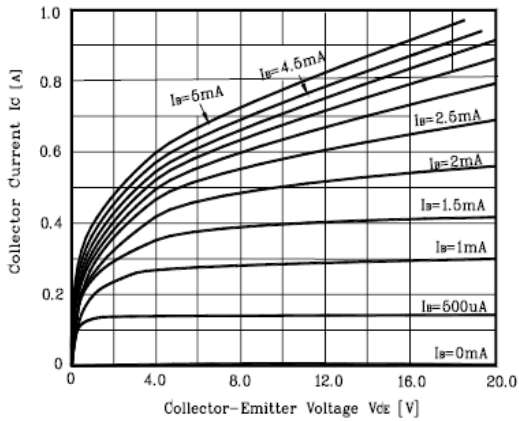

Fig. 5 $I_C - V_{CE}$



SEMTECH ELECTRONICS LTD.



ISO/TS 16949 : 2009 Certificate No. 160713000 | ISO14001 : 2004 Certificate No. 7116 | ISO 9001 : 2008 Certificate No. 90719410 | BS-OHSAS 18001 : 2007 Certificate No. 7116 | IECQ QC 080000 Certificate No. PRC-HSPM-1485

2SC2073U

SOT-89 PACKAGE OUTLINE

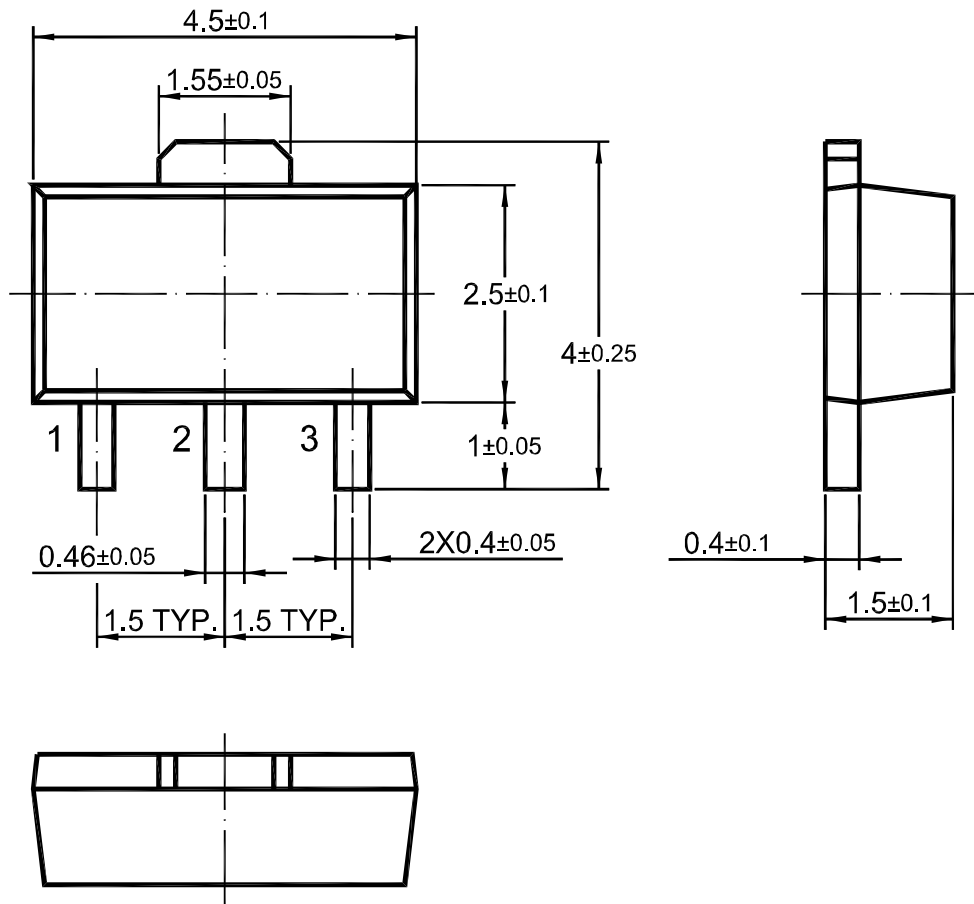

Dimensions in mm

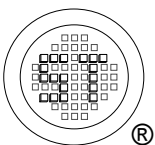

SEMTECH ELECTRONICS LTD.



Dated : 20/02/2016 Rev: 03