

2SA1900U

PNP Silicon Epitaxial Planar Transistor

Medium power transistor

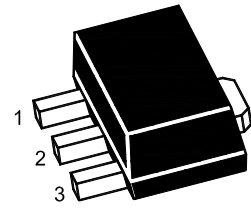

1.Base 2.Collector 3.Emitter
SOT-89 Plastic Package

Absolute Maximum Ratings ($T_a = 25^\circ\text{C}$)

Parameter	Symbol	Value	Unit
Collector Base Voltage	$-V_{CBO}$	60	V
Collector Emitter Voltage	$-V_{CEO}$	50	V
Emitter Base Voltage	$-V_{EBO}$	5	V
Collector Current	$-I_C$	1	A
Collector Current ($P_w = 20$ ms)	$-I_{CP}$	2	A
Collector Power Dissipation	P_C	0.5 2 ¹⁾	W
Junction Temperature	T_j	150	$^\circ\text{C}$
Storage Temperature Range	T_{stg}	- 55 to + 150	$^\circ\text{C}$

¹⁾When mounted on a 40 x 40 x 0.7 mm ceramic board.

Characteristics at $T_a = 25^\circ\text{C}$

Parameter	Symbol	Min.	Typ.	Max.	Unit
DC Current Gain at $-V_{CE} = 3$ V, $-I_C = 500$ mA	h_{FE}	120	-	270	-
Collector Base Cutoff Current at $-V_{CB} = 40$ V	$-I_{CBO}$	-	-	100	nA
Emitter Base Cutoff Current at $-V_{EB} = 4$ V	$-I_{EBO}$	-	-	100	nA
Collector Base Breakdown Voltage at $-I_C = 50$ μA	$-V_{(BR)CBO}$	60	-	-	V
Collector Emitter Breakdown Voltage at $-I_C = 1$ mA	$-V_{(BR)CEO}$	50	-	-	V
Emitter Base Breakdown Voltage at $-I_E = 50$ μA	$-V_{(BR)EBO}$	5	-	-	V
Collector Emitter Saturation Voltage at $-I_C = 500$ mA, $-I_B = 50$ mA	$-V_{CE(sat)}$	-	-	0.4	V
Transition Frequency at $-V_{CE} = 5$ V, $I_E = 50$ mA, $f = 100$ MHz	f_T	-	150	-	MHz
Collector Output Capacitance at $-V_{CB} = 10$ V, $f = 1$ MHz	C_{ob}	-	20	-	pF

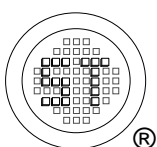

SEMTECH ELECTRONICS LTD.



ISO/TS 16949 : 2009
Certificate No. 180713000

ISO14001 : 2004
Certificate No. 7116

ISO 9001 : 2008
Certificate No. 00719410

BS-OHSAS 18001 : 2007
Certificate No. 7116

IECQ QC 080000
Certificate No. PFC-18P16-1485-1

Dated: 20/01/2016 Rev: 03

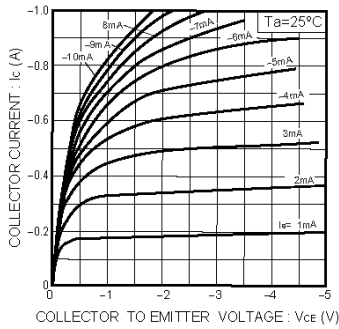

Fig.1 Grounded emitter output characteristics

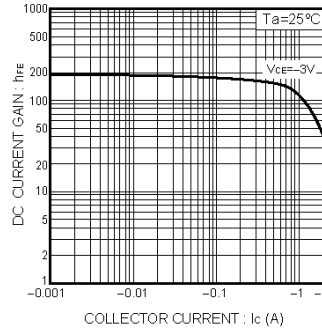

Fig.2 DC current gain vs. collector current

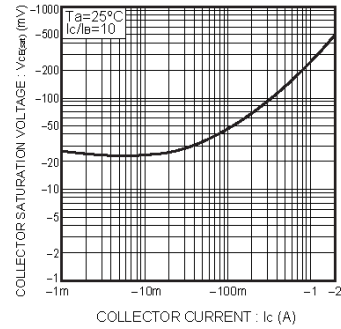

Fig.3 Collector-emitter saturation voltage vs. collector current

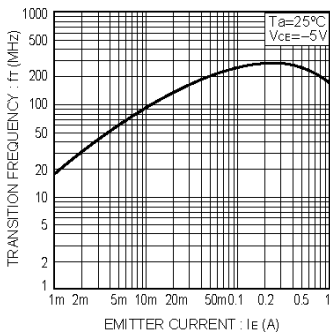

Fig.4 Gain bandwidth product vs. emitter current

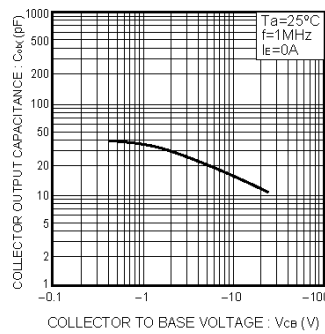

Fig.5 Collector output capacitance vs. collector-base voltage

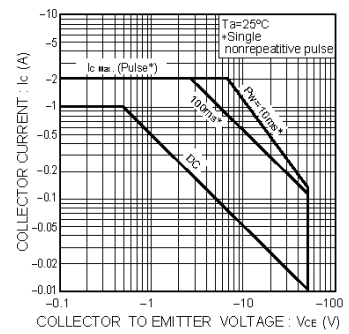
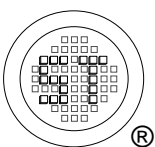

Fig.6 Safe operating area



SEMTECH ELECTRONICS LTD.



ISO/TS 16949 : 2009
Certificate No. 180713000



ISO14001 : 2004
Certificate No. 7116



ISO 9001 : 2008
Certificate No. 60719410



BS-OHSAS 18001 : 2007
Certificate No. 7116



IECQ QC 080000
Certificate No. PFC-18P16-1483

2SA1900U

SOT-89 PACKAGE OUTLINE

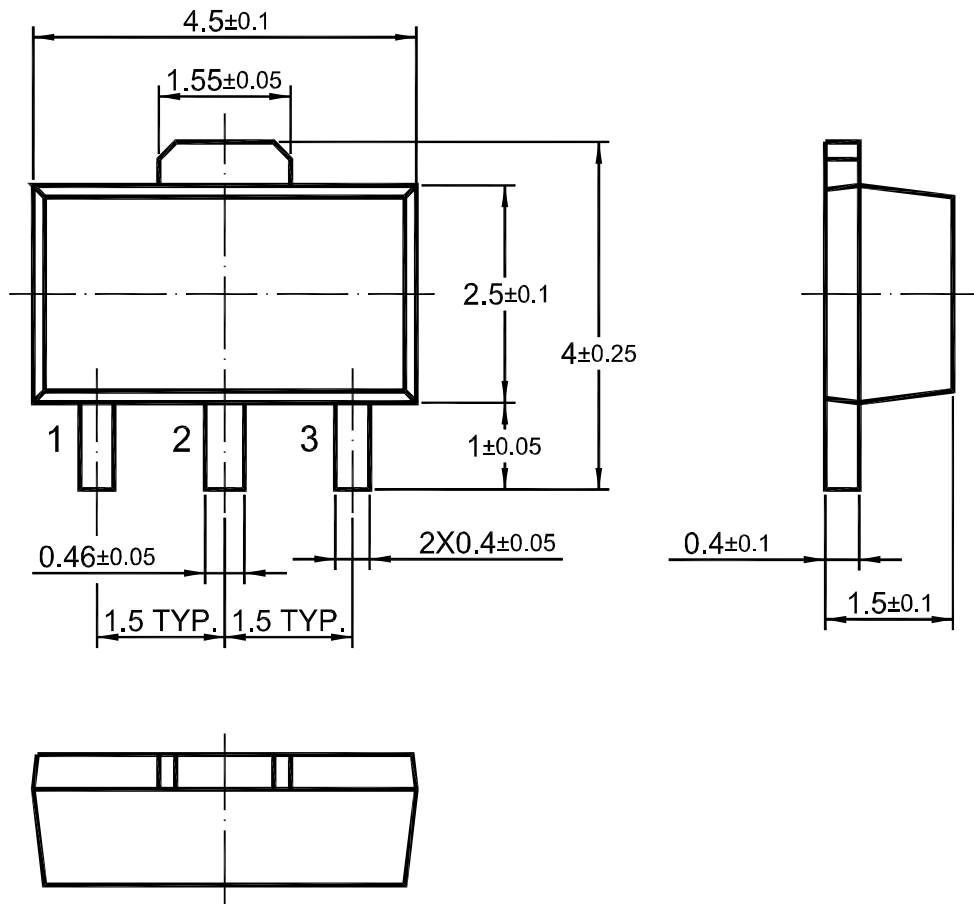

Dimensions in mm

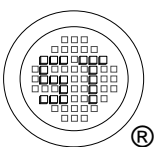

SEMTECH ELECTRONICS LTD.



ISO/TS 16949 : 2009
Certificate No. 180713000



ISO14001 : 2004
Certificate No. 7116



ISO 9001 : 2008
Certificate No. 50719410



BS-OHSAS 18001 : 2007
Certificate No. 7116



IECQ QC 080000
Certificate No. PFC-HSPM-1485-1

Dated: 20/01/2016 Rev: 03